



## *Classic* TBI 150 E1

Air cooled

Very compact and ergonomic

Screw-on fume shroud

### Technical data

#### MIG/MAG semi-automatic fume extraction welding torch TBI 150 E1

Rating at 60% duty cycle  
(10 min. cycle)

- Mixed gas: 150 A  
- CO<sub>2</sub>: 180 A

Cooling method air cooling

Wire diameter 0.6 - 1.0 mm

Gas flow 8 l/min

Technical specification according to IEC 60974-7

Weight with 1.5m cable 1.10 kg

Connection Euro-Central connector,  
other connectors (e.g. CLOOS®, ESAB®,  
Lincoln®) available upon request.

Torch rating will be reduced when using pulsed-arc power sources.  
Custom lengths of the cable assembly are available upon request.

### Ordering Information

TBI 150 E1 ESG, 50° bent 252P3Y03\_0\*

\* At the blank, please insert 3, 4 or 5 for a torch length of 3, 4 or 5 m.

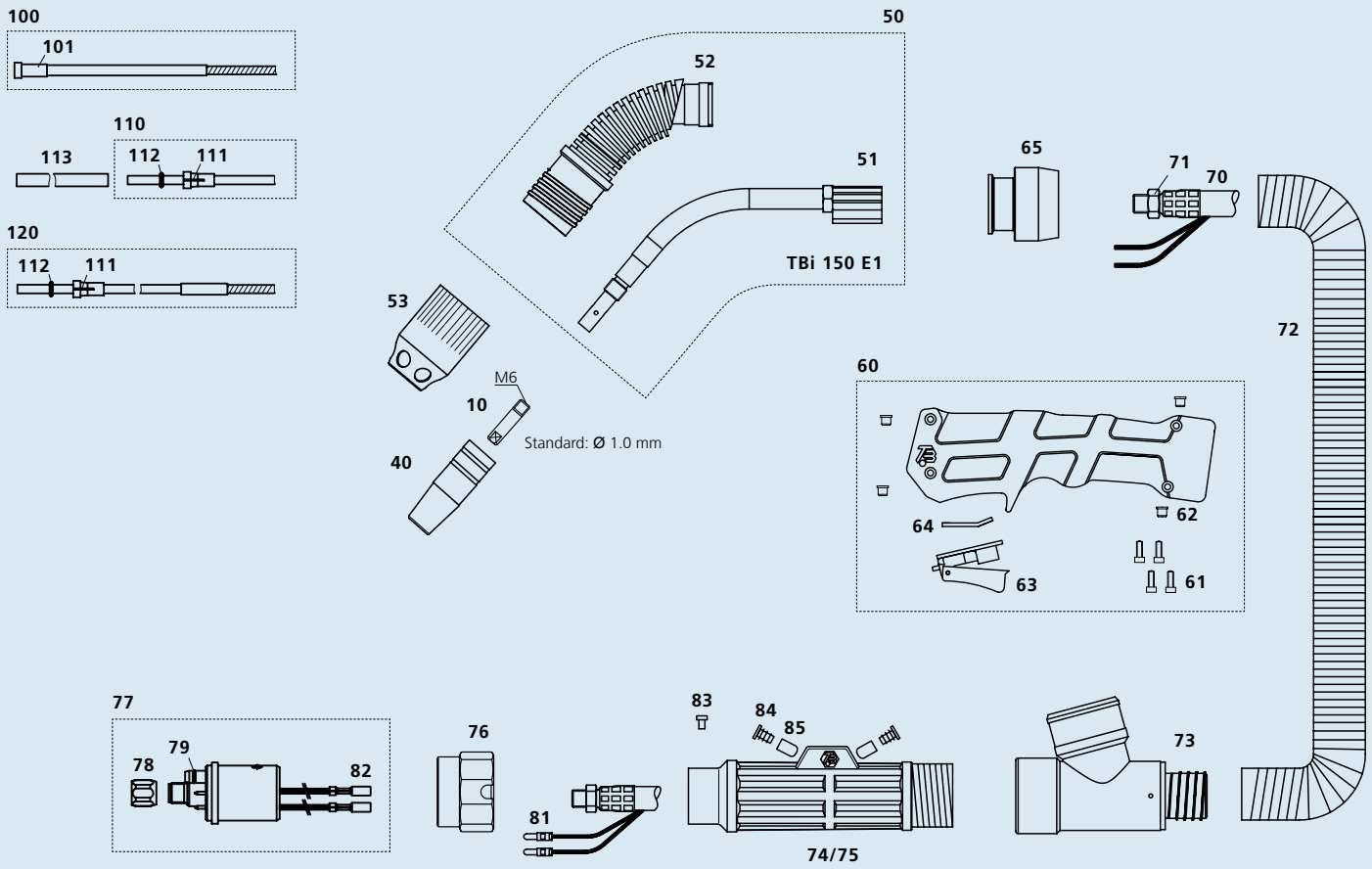

Pos. Description

Part. No.

Pos. Description

Part. No.

### Contact tips

▶ 10	Contact tip M6x25, Ecu	340P_1073*
10	Contact tip M6x25, CuCrZr	340P_3073*
10	Contact tip M6x25 Alu, Ecu	341P_1073*

### Gas nozzles

▶ 40	Nozzle con. diam. 12.0 mm, screw-on	345P002002
------	-------------------------------------	------------

### Spare parts

50	Torch neck TBi 150 E1, cpl.	252P101005
51	Inner tube TBi 150 E1	252P101001
52	Outer tube TBi 150 E1	252P101002
53	Fume shroud TBi 150 E1	252P102006
60	Handle cpl., blue, micro switch, TBi E1	380P916001
61	Socket cap screw M4x10	109P091204
62	Threaded bush M4	252P102016
63	Micro switch, red, 3 poles	385P033011
64	Sealing plate for handle TBi E1	252P102017
-	Gasket for handle TBi E1	252P102015
65	Handle fitting for 29 mm fume hose	252P102026
70	Coaxial cable cpl., 16 sqmm	359P1611_0*
71	Hex nut M10x1	101P002005
72	Fume extraction hose D=29 mm	306P293600
73	T-joint cpl. for 29 mm fume hose	200P101013
74	Cable support housing (only with pos. 75)	701P102070
75	Cable support cover (only with pos. 74)	701P102071
76	Adaptor nut	701P001013
77	Central adaptor ESG cpl., 2 poles, moveable pins	701P001048
78	Sleeve nut M10x1	701P002005
79	O-ring 4.0x1.0 mm (gas nipple)	365P100040
81	Insulated connector, male, round	375P000004

82	Insulated connector, female, round	375P000003
83	Slotted screw M4x6	100P008401
84	Square cap	200P102006
85	Cap for water connector	395P000004

### Wire guides

100	Liner w/ insulation white (x.40 m) for wire 0.6-0.9	324P1338_4*
▶ 100	Liner w/ insulation blue (x.40 m) for wire 0.8-1.0	324P1545_4*
101	Collet for liner 1.3x3.8 mm	330P015040
101	Collet for liners dia. 4.5 mm	330P025045
110	Teflon liner blue (x.50 m) for wire 0.6-0.9	326P1540_5*
111	Collet for teflon and PA liner 4.0 mm	331P020040
112	O-ring 3.50x1.50 mm (teflon liner)	365P150035
113	Support tube 5x4.4 mm, L=150 mm	329P544150
120	PA-Alu wire guide (x.50 m) for wire 1.0-1.2	328P2040_A*

▶ = Standard equipment

\* At the blank, please insert suitable information for torch length or wire diameter, e.g. 08 for 0.8 mm or 3 for 3 m.

© 2008 TBi Industries GmbH. All rights reserved. Subject to change without notice. Warranty only when using original TBi consumables and spare parts. Excerpts and reprints not permitted. Nr. DOKP113102, 01/2008.

TBi Industries GmbH  
Ruhberg 14  
D-35463 Fernwald-Steinbach  
P.O. Box 67  
D-35461 Fernwald-Steinbach

Tel. + 49 6404 9171-0  
Fax. + 49 6404 9171-40  
Internet: www.tbi-industries.com  
E-mail: info@tbi-industries.com