



RoboMIG TBi RM 90W

Technical data

Robot welding torch TBi RM 90W

Rating at 100% duty cycle
(10 min. cycle)

- Mixed gas: 19.0 kW (approx. 500 - 550 A)

Cooling method 2-circuit water cooling

Wire diameter 0.8 - 1.6 mm

Gas consumption from 8 l/min

Gas flow 1 channel for protective and
blow-out gas

Weight approx. 0.70 kg

Technical specification according to IEC 60974-7

Connection TBi WH flange compatible to our
WH cable assemblies, PowerPull
wire feeders and quick-change
adaptor.

Torch rating will be reduced when using pulse-arc power sources.

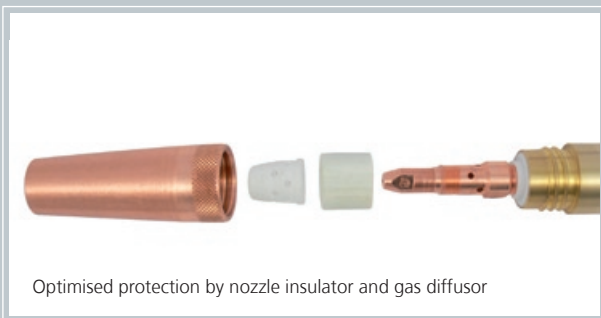

Ordering information

**TBi RM 90W,
Torch neck without consumables**
Please order consumables separately as needed.

	universal	for direct clamping		for quick-change adaptor	
	0°	22°	45°	22°	45°
	671P101231	671P101234	671P101235	671P101232	671P101233

Dimensions

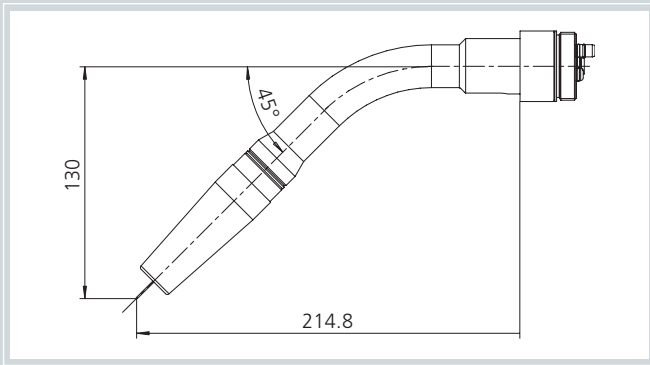
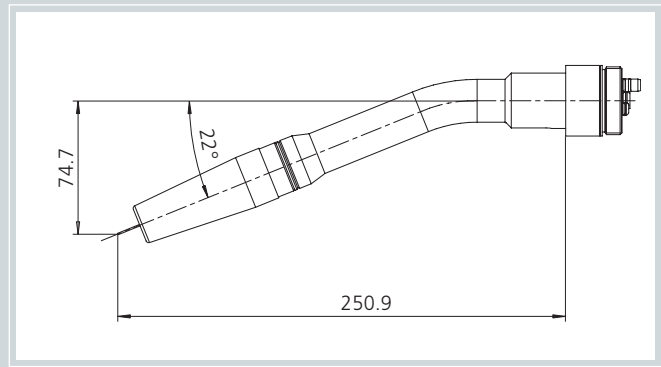
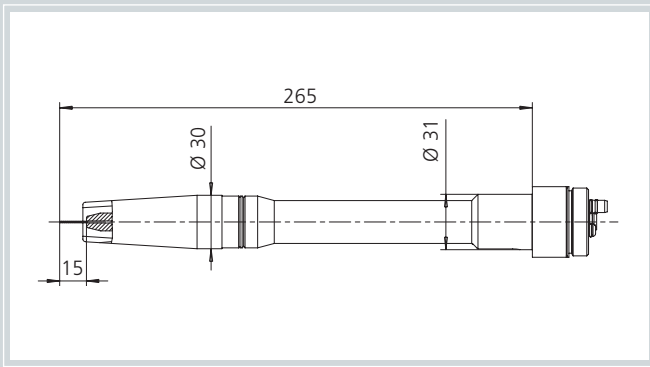

The TBI RoboMIG welding torch RM 90W has a very rugged design with a stainless steel outer tube. Therefore, the factory set TCP will neither be changed by thermal stresses during welding nor collisions. This fact greatly simplifies maintenance of the welding cell.

Due to large cross sections, this torch features specially good cooling properties.

When ordering, please make sure to choose the correct type for either direct clamping or for the chick-change adaptor. The torches are adjusted differently and must be used only for the corresponding mounting option.

Spare parts and consumables

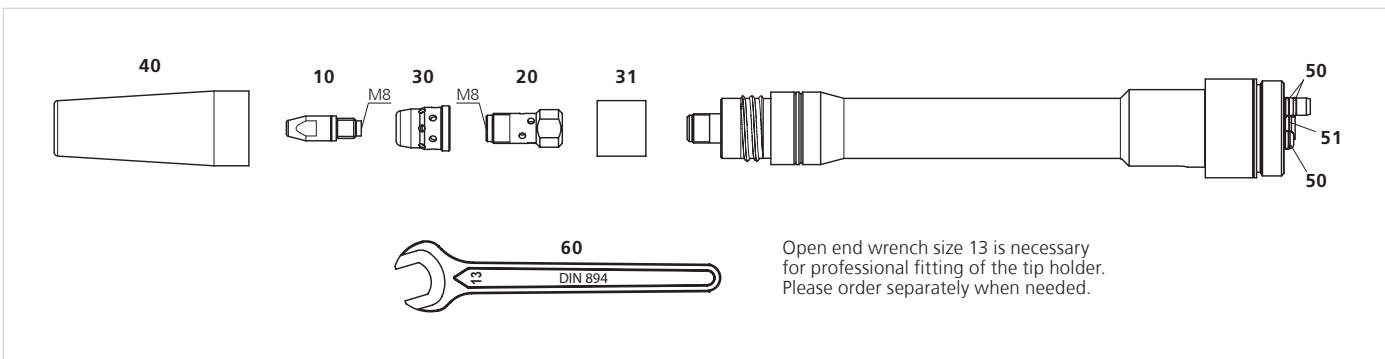

Open end wrench size 13 is necessary for professional fitting of the tip holder. Please order separately when needed.

Pos.	Description	Part no.
Contact tips		
10	Contact tip M8x30, ECu	340P_1262*
▶ 10	Contact tip StarTip M8x30	344P_6262*
Tip holder		
▶ 20	Tip holder M8, forced contact	661P102014
Gas diffuser / nozzle insulator		
▶ 30	Gas diffuser ceramic	671P102038
▶ 31	Nozzle insulator	346P019671

Pos.	Description	Part no.
Gas nozzle		
▶ 40	Nozzle con. NW 16.0 mm	345P023661
Spare parts		
50	O-ring 5.0x1.2 mm	365P120050
51	O-ring 7.0x1.5 mm	365P150070
Accessories		
60	Open end wrench, size 13 mm	391P102026

▶ = Standard equipment

* At the blank, please insert suitable information for wire diameter, e.g. 08 for 0.8 mm.

© 2008 TBI Industries GmbH. All rights reserved. Subject to change without notice. Warranty only when using original TBI consumables and spare parts. Excerpts and reprints not permitted. Nr. DOKP141072, 09/2008.