

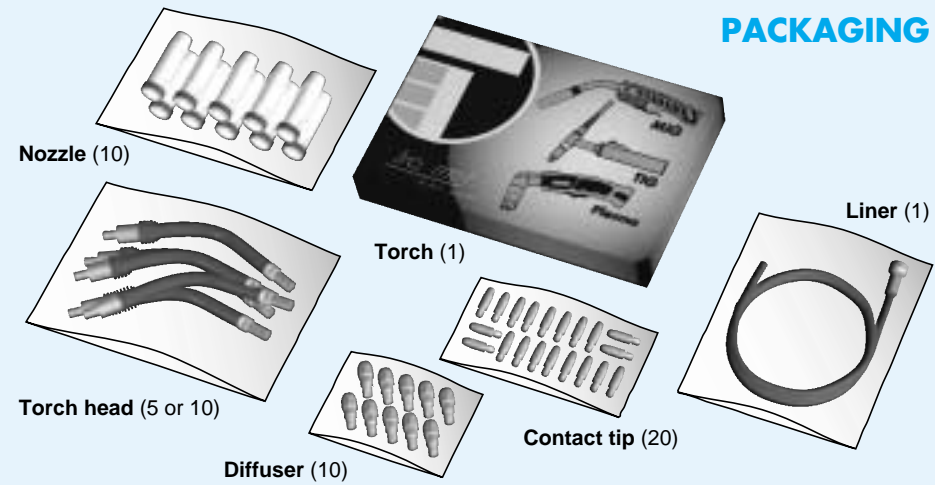

PACKAGING



MEGA 5

	Code	m	Feet	Liner	Adaptor
TW-MK	MA 5500	3	10	GM 13	AS 47
	MA 5501	4	12	GM 13	AS 47
	MA 5502	4.6	15	GM 13	AS 47
EURO-TW FIXED PINS	MA 5550	3	10	GM 13	AR 81
	MA 5551	4	12	GM 13	AR 81
	MA 5552	4.6	15	GM 13	AR 81
EURO-TW SPRING PINS	MA 5565	3	10	GM 13	AR 83
	MA 5566	4	12	GM 13	AR 83
	MA 5567	4.6	15	GM 13	AR 83

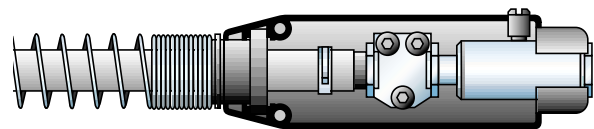

FB 2216
Optional

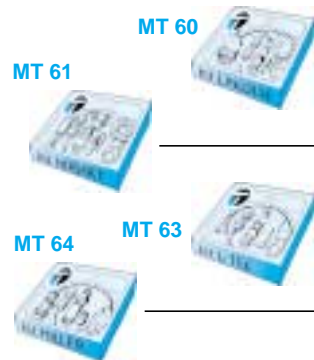

trafimet[®]
your welding partner

TRAFIMET spa claim that all items on this catalogue are manufactured in conformity with the "low voltage" CE 73/23 directive as per EN 50078 standard. The company reserve the right to modify any products without notice. TRAFIMET spa is the registered owner of all trademarks, patents and models.

Copyright © June 1997 • by TRAFIMET spa (Print 05/98)

EA 0543



EN 50078

MEGA 5

MIG TORCHES

trafimet[®]
your welding partner

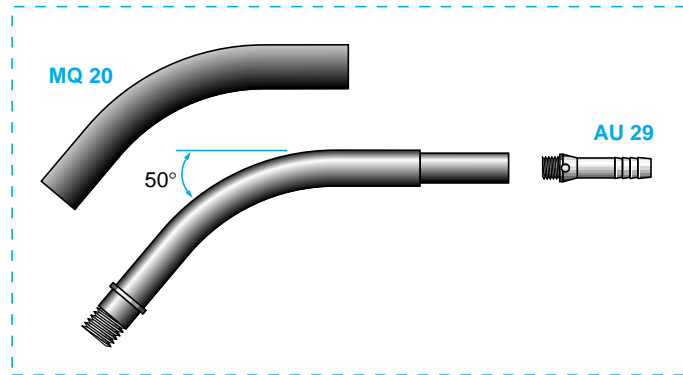

TW5 MF 31 65-60
Spare parts for original TW5 torch
Ricambi per torcia originale TW5
Ersatzteile für Original Brenner TW5
Pièces d'usure pour torche originale TW5

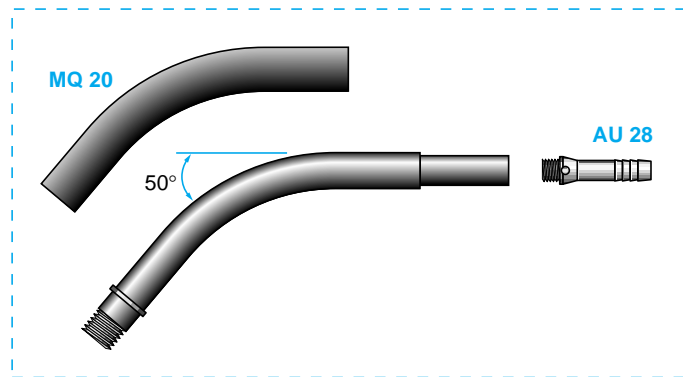

MEGA 5 MF 88
Only for MEGA 5
Solo per MEGA 5
Nur für MEGA 5
Seulement pour MEGA 5

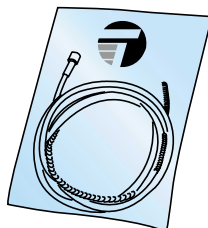
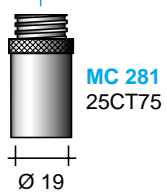
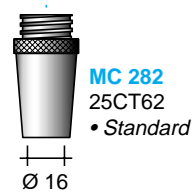
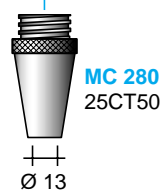
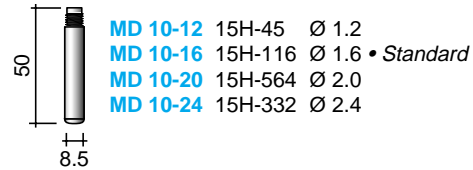

	wire 0.9 + 1.2	wire 1.2 + 1.6	wire 1.6 + 2.0
STEEL	4.6 GM 226 44-3545-15 (Green)	GM 13 44-116-15 (Gray)	GM 221 44-567-15 (Yellow)
TEFLON ALUMINIUM WIRE	4.6 GM 230 42N3545-15 (Red)	GM 231 44N-116-15 (Yellow)	-

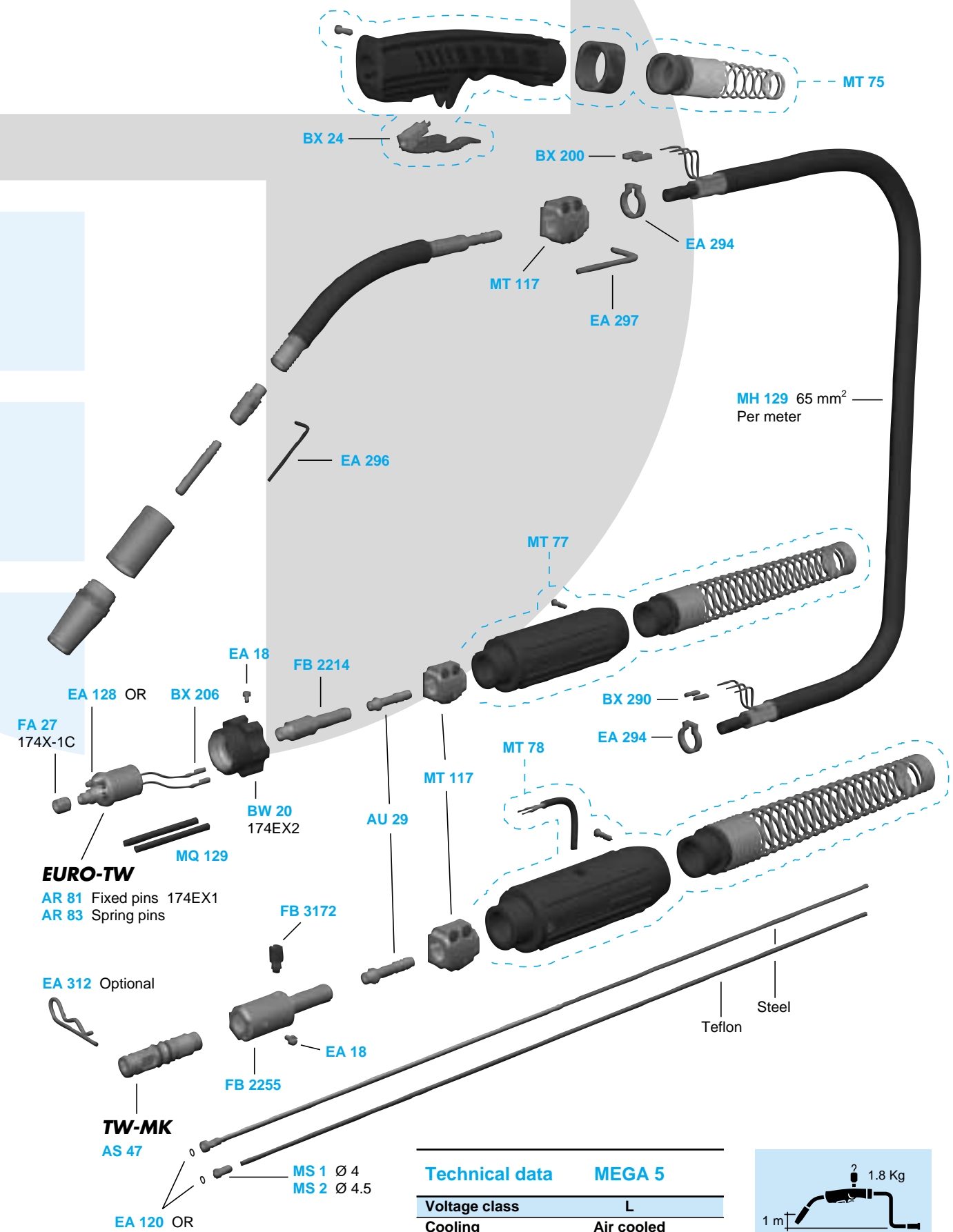

Technical data	MEGA 5
Voltage class	L
Cooling	Air cooled
Wire Ø mm	1.2 • 1.6 • 2.0
Duty cycle	500A 60% CO ₂ 400A 60% Mix • 100% CO ₂

